

DESCRIPTION

- Designed for slate, simulated slate, shake, asphalt shingle and metal roofs
- Can be glued down with SB-190 adhesive
- Powder coated to match roofing material color
- Overall dimensions: 8-1/8" L X 3" W X 2-7/8" H

MATERIALS

- 16 ga. ElectroGalvanized Steel
- 48 oz. Copper
- Aluminum (.063" thick)
- Stainless Steel
- Cor-Ten®

COLORS/FINISHES

- ElectroGalvanized Steel
- Mill finish Copper
- Mill finish Aluminum
- Mill finish Stainless Steel
- Powder coating available in RAL Standard colors
- Visit www.tra-mage.com to see color chart

NOTE: Due to specific job conditions, TRA-Mage will only warranty a snow retention system/layout that has been designed by TRA-Mage.



SNOW BRACKET E-S FOR NEW CONSTRUCTION USED ON: SLATE, SIMULATED SLATE, SHAKE, ASPHALT SHINGLE & METAL ROOFS

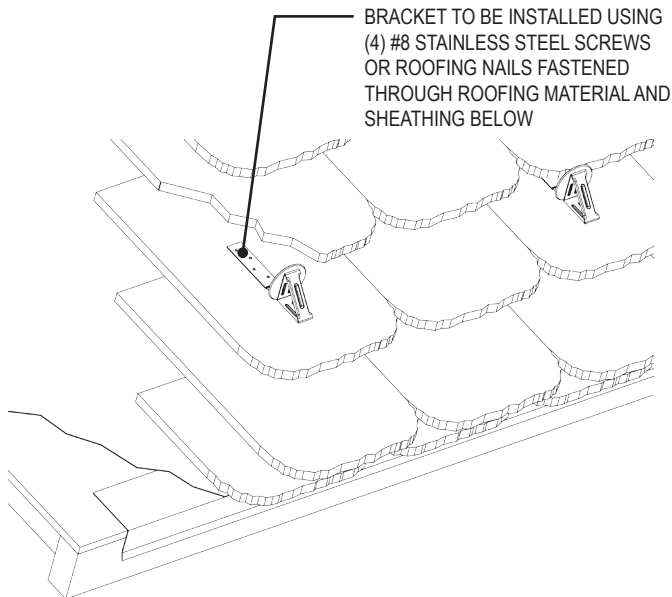

Bracket is installed with triangular end of bracket at eave end of roofing material and upper end under course above.

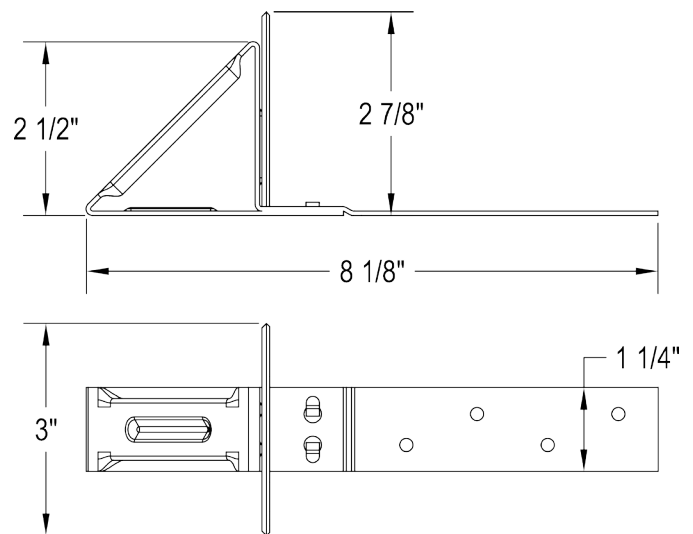

BRACKET INSTALLATION

DO NOT SCALE

BRACKET DIMENSIONS

DO NOT SCALE